

LEGEND	
	CITY BUS ROUTE
	VILLAGE TRANSIT BUS END ROUTE
	VILLAGE TRANSIT W.C. ROUTE

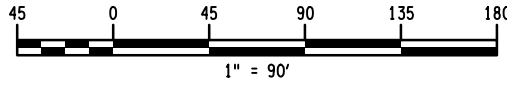

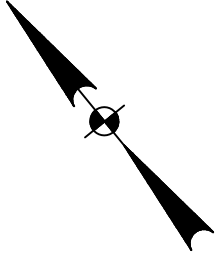

FILE = N:\Projects\2018\118-005 - Monroe Commons\Working\CADD\Drawings\118-005-Fig.opt.dwg, 8/2/2023

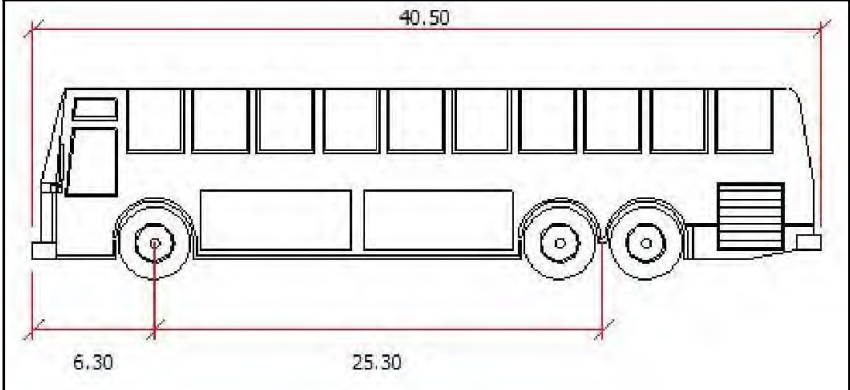
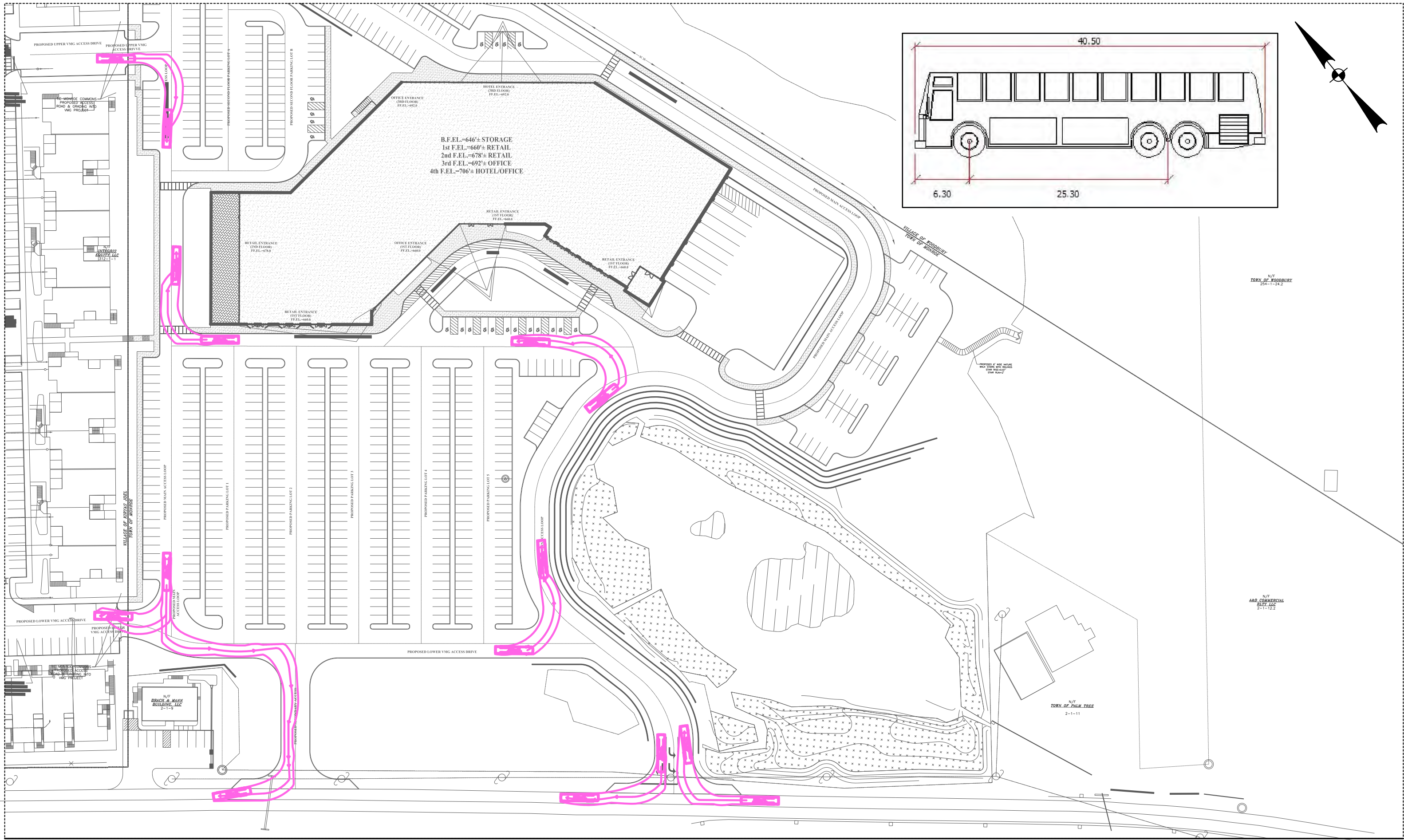
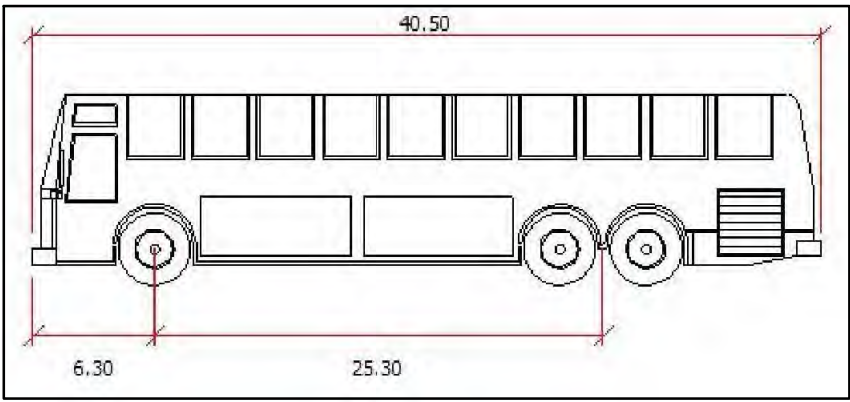
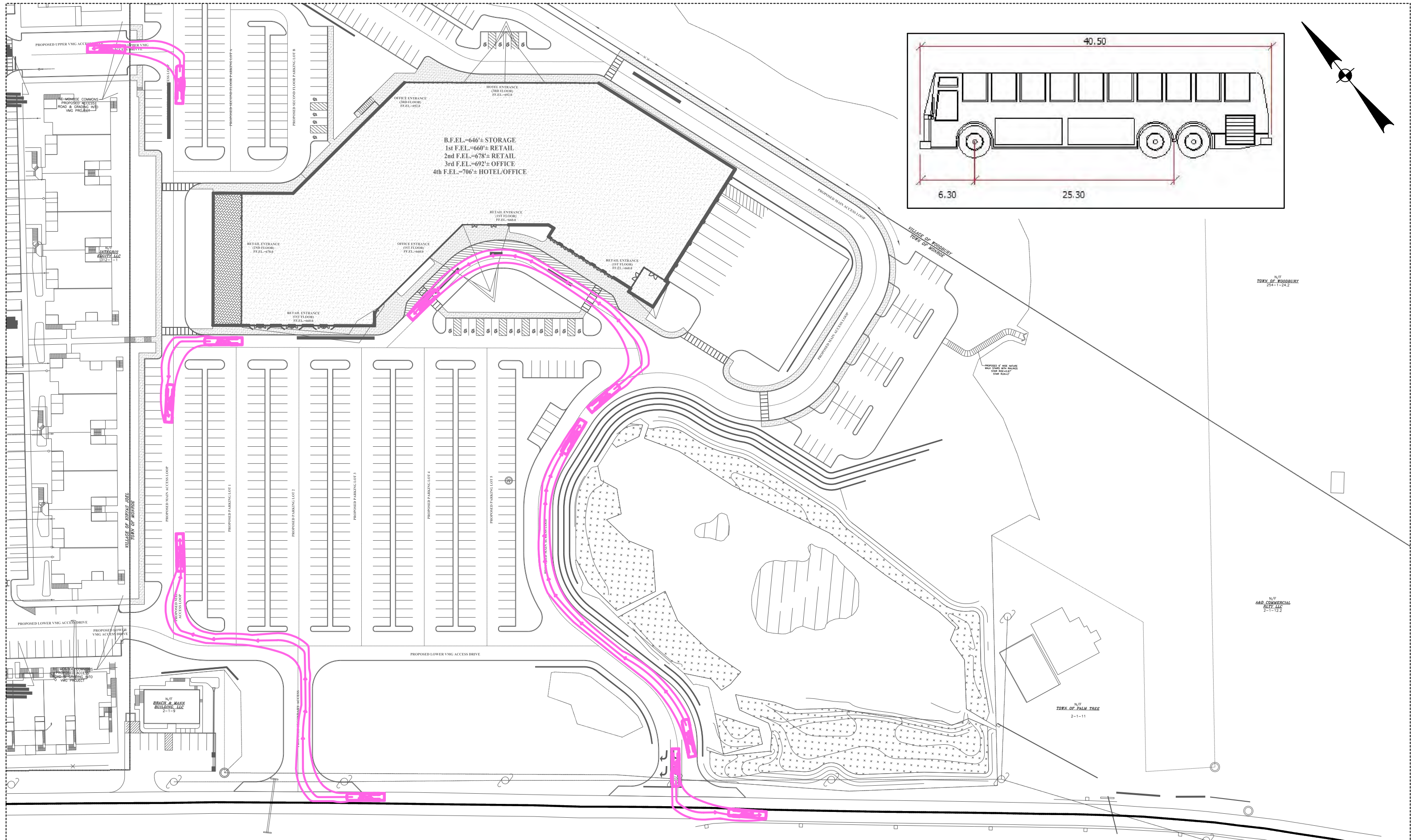

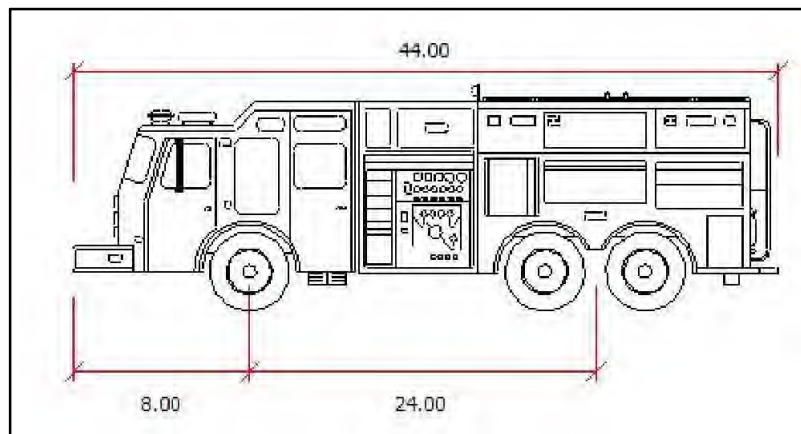
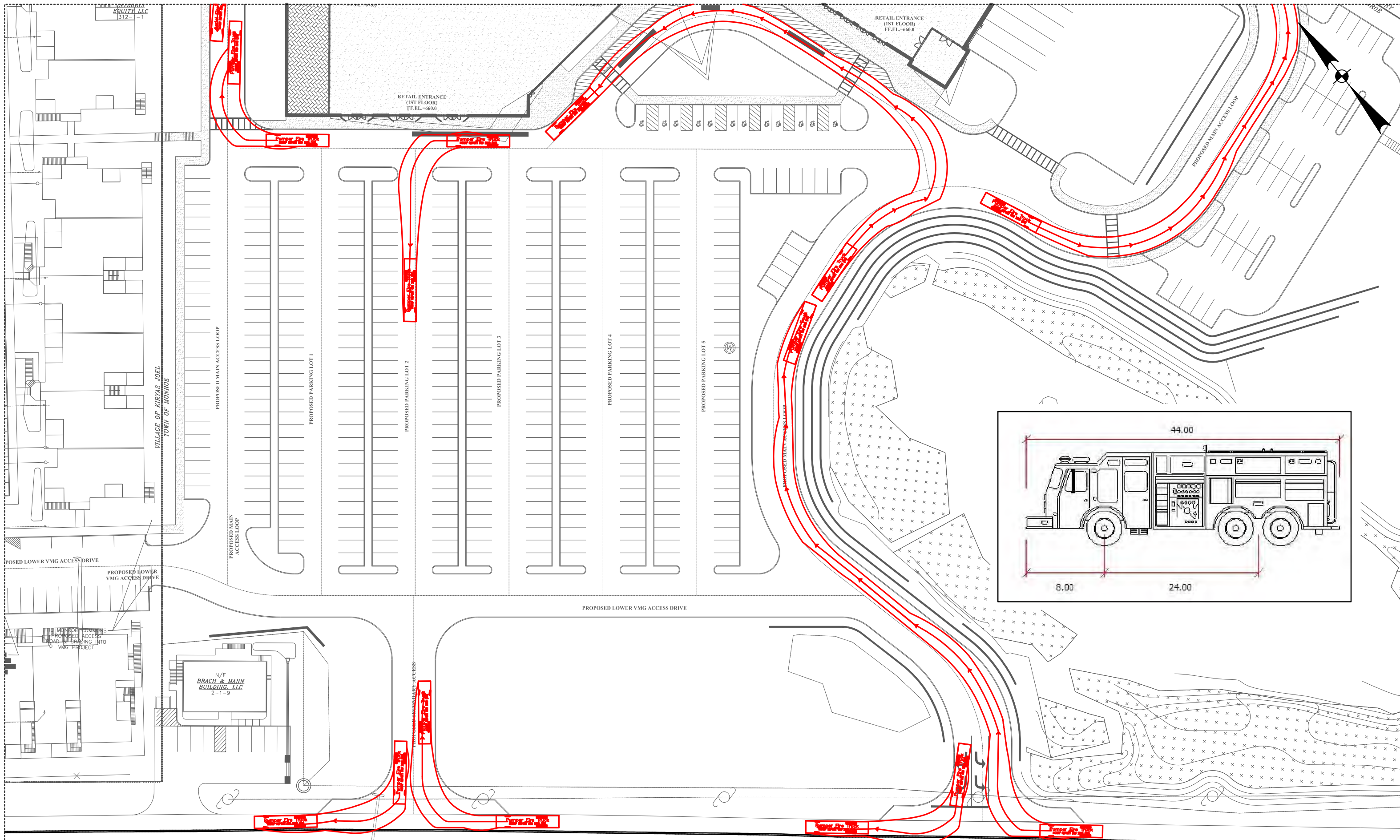

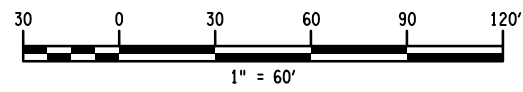
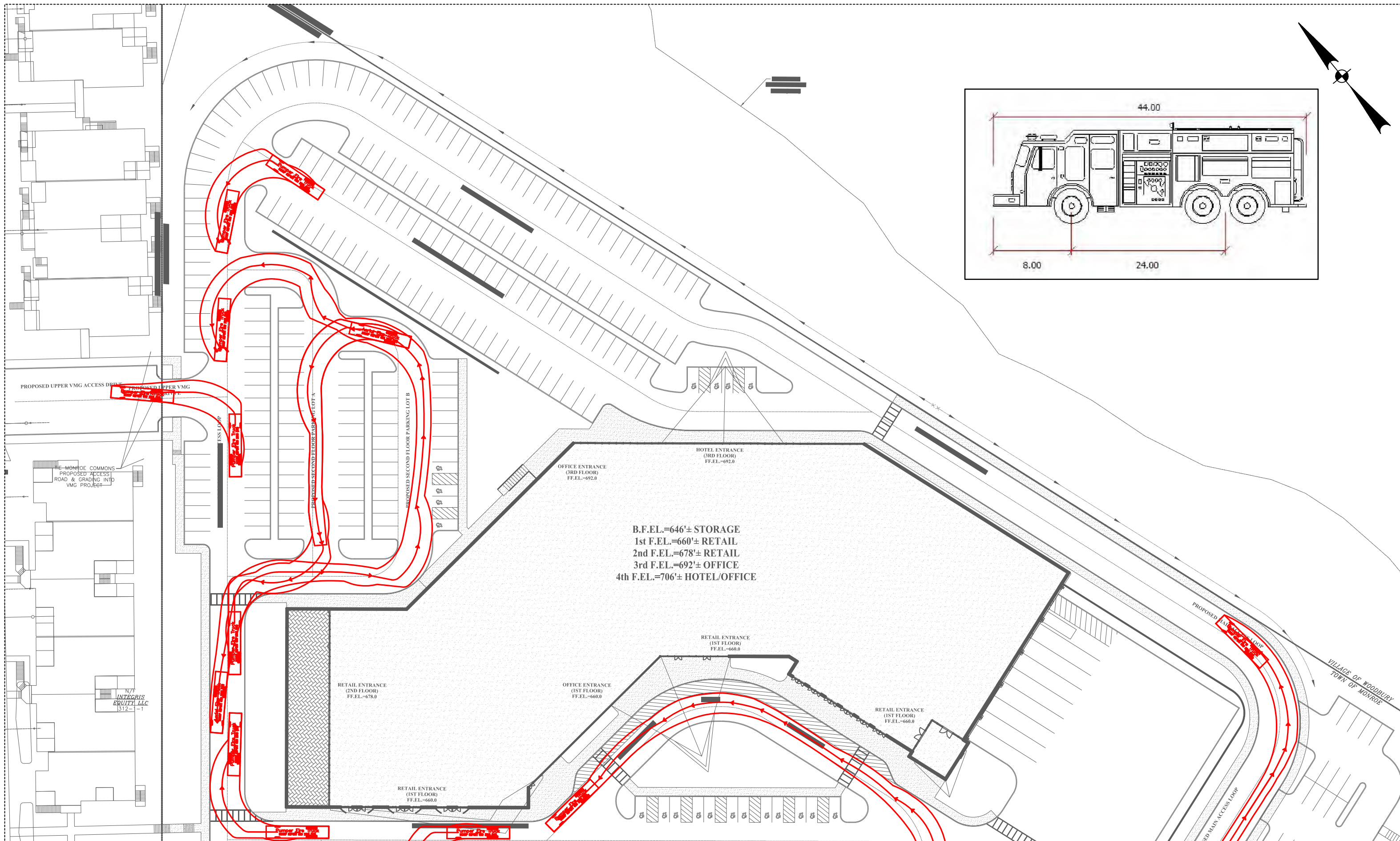

B.F.E.L.=646± STORAGE
 1st F.E.L.=660± RETAIL
 2nd F.E.L.=678± RETAIL
 3rd F.E.L.=692± OFFICE
 4th F.E.L.=706± HOTEL/OFFICE

B.F.E.L.=646± STORAGE
 1st F.E.L.=660± RETAIL
 2nd F.E.L.=678± RETAIL
 3rd F.E.L.=692± OFFICE
 4th F.E.L.=706± HOTEL/OFFICE

